

SUMIG II
FIRE

SUMIG



CATÁLOGO DE
**TOCHAS DE
SOLDA TIG**

2021/2022

SUMIG III

www.sumig.com



SUMIG

FUNDADA EM 1980, COM MAIS DE 10 MIL CLIENTES ATENDIDOS, A SUMIG É ESPECIALIZADA EM **SOLUÇÕES PARA SOLDA E CORTE.**



Empresa Consolidada



Ampla Rede de Assistência Técnica



Assessoria em Soldagem



Referência Internacional em Soluções para Solda e Corte



Maior Fabricante de Tochas MIG/MAG, TIG, Plasma e Robô da América Latina



Mais de 2 mil Revendedores em todo o Brasil



Equipamentos de Solda e Corte para empresas de todos os segmentos



Mais de 700 Células de Soldagem Robotizadas comercializadas no Brasil e no Exterior

SUMIG

TOCHAS MANUAIS/Hand Torches
04

Modelo Model	Refrigerada à Água	Corrente (A)		Eletrodo (mm) Electrode (mm)	Página Page
		DC	AC		
SU 9	-	130A	110A	1,00 a 2,38 mm	04
SU 20	Sim	250A	180A	1,00 a 3,17 mm	06
SU 26	-	210A	160A	1,00 a 3,17 mm	08
SU 27	-	210A	160A	1,00 a 3,97 mm	10
SU 18	Sim	350A	250A	1,00 a 3,97 mm	12
SU 19	Sim	400A	280A	1,00 a 4,76 mm	14
SU 40	-	270A	210A	1,59 a 4,76 mm	16
SU 50	Sim	520A	360A	1,59 a 4,76 mm	18

TOCHAS P/ APLICAÇÕES ESPECIAIS/ Special Application Torches
20

Modelo Model	Refrigerada à Água	Corrente (A)		Eletrodo (mm) Electrode (mm)	Página Page
		DC	AC		
SU 27 Precision	-	210A	160A	1,00 a 3,97 mm	20
SU 27 Max	-	300A	210A	1,00 a 3,97 mm	20
SR 82	Sim	500A	350A	1,59 a 4,76 mm	20

OPCIONAIS LINHA TIG/ Optional
21
Opção de Montagem e Opcionais
**Página
Page**
21



Características Técnicas Technical Data

Cinco Modelos de Corpo da Tocha em Ângulo Flexível ou Reto
Five Models of Torch Bodies in Angle Flexible or Straight
Cordoalha Estanhada
Tinned Conductor

Indicações Recommendation

Serviços Leves
Light Works

Catálogo Digital
QR Code



Corrente - Current



1,0 - 2,38

Eletrodo (mm)
Electrode (mm)

E06/22-V4

Código/Code	Descr./Descr.	Corpo/Body	Tipo/Type	Engate/Coupling	Med./Mes.	Estoque/Stock
0600.3001	Tocha de Solda TIG SU9	Silicone Silicon	Registro Valve	Convencional Standard		●
0600.3006	SU9 TIG Welding Torch			Engate Rápido Fast Coupling	9,00mm	●
0600.3011				Engate Rápido Fast Coupling	12,80mm	●

Tocha/Torch TIG SU9

Código/Code	Descr./Descr.	Corpo/Body	Tipo/Type	Engate/Coupling	Med./Mes.	Estoque/Stock
0600.3002	Tocha de Solda TIG SU9	Silicone Silicon	Acionamento Trigger	Convencional Standard		●
0600.3007	SU9 TIG Welding Torch			Engate Rápido Fast Coupling	9,00mm	●
0600.3012				Engate Rápido Fast Coupling	12,80mm	●

Tocha/Torch TIG SU9

Legenda/Legend: ● Produto Regular ● Produto Sob Demanda

Foto/Photo	Pos.	Código/Code	Descrição/Description	Med./Mes.
	01	0600.2105	Bocal de Cerâmica Alumina Nozzle	n° 04 ø6,5mm
		0600.2106		n° 05 ø8mm
		0600.2107		n° 06 ø9,5mm
		0600.2108		n° 07 ø11mm
		0600.2109		n° 08 ø12,5mm
	02	0600.2016	Corpo Fixador Collet Body	1,59mm 1/16"
		0600.2017		2,38mm 3/32"
	03	0600.1004	Anel Inferior Bottom Cup Gasket	

Foto/Photo	Pos.	Código/Code	Descrição/Description	Med./Mes.
	04	0600.1006	Corpo da Tocha Silicone Silicon Torch Body	p/uso de Registro W/Valve
	05	0600.1007	Corpo da Tocha Silicone Silicon Torch Body	p/uso de Acionamento for Trigger

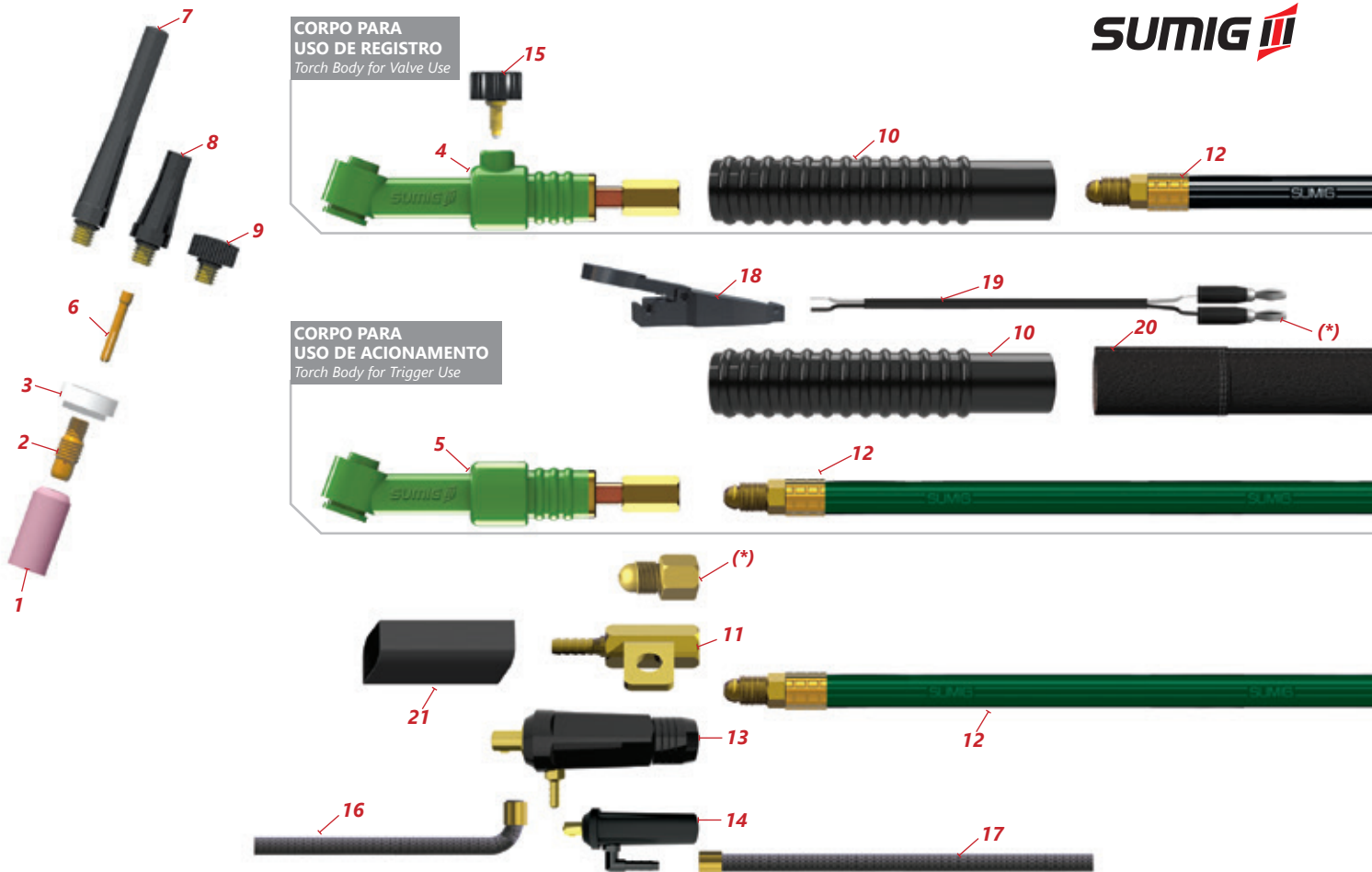

(*) Linha de Opcionais/Optional Line

Foto/Photo	Pos.	Código/Code	Descrição/Description	Med./Mes.	Foto/Photo	Pos.	Código/Code	Descrição/Description	Med./Mes.			
	06	0600.1009	Fixador Collet	1,00mm		13	0801.2085	Conector Macho TIG 12,80mm c/Entrada do Gás TIG Male Connector w/ 12,80mm Gas Input				
		0600.2018		1,59mm 1/16"								
		0600.1011		2,00mm 5/64"								
		0600.2019		2,38mm 3/32"								
	05	2210.0043	Fixador Curto Tocha Retã Short Collet for Straight Torch	1,59mm 1/16"		14	0801.2090	Conector Macho TIG 9,00mm c/Entrada do Gás TIG Male Connector w/ 9,00mm Gas Input				
		2210.0044		2,38mm 3/32"								
		2210.0045		3,17mm 1/8"								
	07	0600.2015	Capa Longa Long Cap	143mm		15	0600.1020	Registro do Corpo Torch Valve				
		0600.1016		105mm								
	08	0600.1015	Capa Média Medium Cap	42mm		16	0600.1093	Mangueira de Entrada do Gás Input Hose Gas	0,40m 3/16"			
	09	0600.2014	Capa Curta Short Cap						17	0600.1094		1,50m 5/16"
	10	0600.2104	Punho da Tocha Torch Handle			18	0600.1023	Acionamento da Tocha Torch Trigger				
	11	0600.1474	Terminal do Cabo Gás e Força Gas and Power Cable Terminal			19	0600.1022	Cabo de Acionamento 4m Trigger Cable 4m				
	12	0600.1019	Cabo de Gás e Força p/Sistema Convencional e Engate Rápido 12,80mm Gas-Power Cable for Standard System and 12,80mm Fast Coupling			20	0600.1028	Capa Protetora dos Cabos 3m Cable Protection Cover 3m				
		0600.1068	Cabo de Gás e Força Engate Rápido 9,00mm Gas-Power Cable for 9,00mm Fast Coupling							21	0600.1560	Isolação Termo Retrãtil do Terminal Thermo Retractable Insulation



Características Técnicas Technical Data

Dois Modelos de Corpo da Tocha em Ângulo ou Reto
Two Models of Torch Bodies in Angle or Straight
Cordoalha Estanhada
Tinned Conductor

Indicações Recommendation

Serviços Leves
Light Works

Catálogo Digital
QR Code



Corrente - Current



1,0 - 3,17

Eletrodo (mm)
Electrode (mm)

E06/22-V4

Código/Code	Descr./Descr.	Corpo/Body	Tipo/Type	Engate/Coupling	Med./Mes.	Estoque/Stock
0600.6001	Tocha de Solda TIG SU20 Refrigerada	Silicone Silicon	Acionamento Trigger	Convencional Standard		●
0600.6003	SU20 Water Cooled TIG Welding Torch			Engate Rápido Fast Coupling	12,80mm	●

Tocha/Torch TIG SU20 Refrigerada

Legenda/Legend: ● Produto Regular ● Produto Sob Demanda

Foto/Photo	Pos.	Código/Code	Descrição/Description	Med./Mes.	Foto/Photo	Pos.	Código/Code	Descrição/Description	Med./Mes.					
	01	0600.2105	Bocal de Cerâmica Alumina Nozzle	n° 04 ø6,5mm		03	0600.1004	Anel Inferior Bottom Cup Gasket						
		0600.2106		n° 05 ø8mm				04	0600.1030	Corpo da Tocha Silicone p/uso de Acionamento Silicon Torch Body for Trigger use				
		0600.2107		n° 06 ø9,5mm					0600.1009		1,00mm			
									0600.2108	n° 07 ø11mm	05	0600.1011	Fixador Collet	1,59mm 1/16"
									0600.2109			2210.0043	0600.2019	2,00mm 5/64"
									0600.2045				0600.2045	2,38mm 3/32"
2210.0044	3,17mm 1/8"													
	02	0600.2016	Corpo Fixador Collet Body	1,59mm 1/16"		06	0600.2015	Capa Longa Long Cap	143mm					
		0600.2017		2,38mm 3/32"			0600.1016	105mm						
		0600.2044		3,17mm 1/8"		0600.1015	0600.1015	Capa Média Medium Cap	42mm					
							0600.1014	Capa Curta Short Cap						

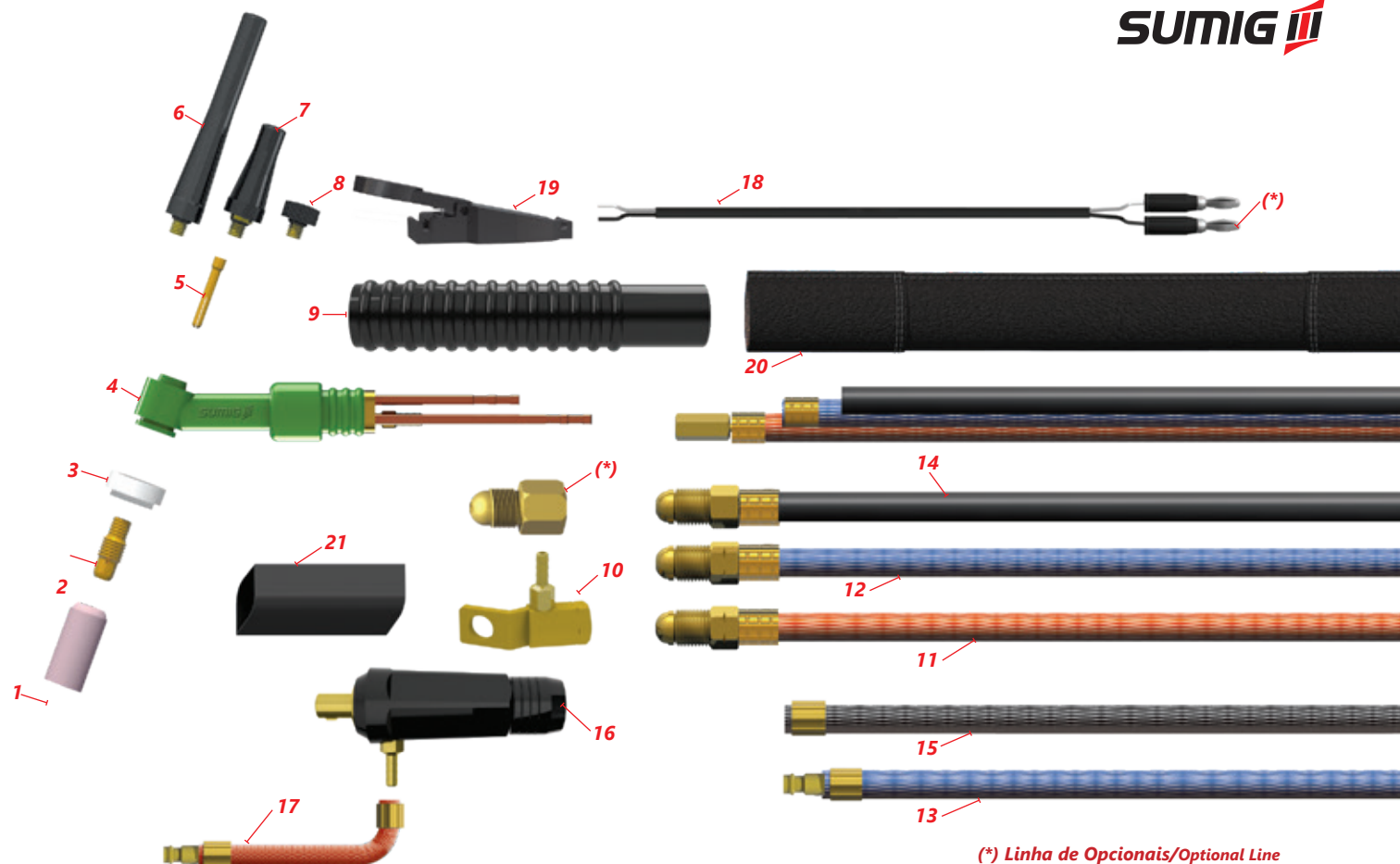

(*) Linha de Opcionais/Optional Line

Foto/Photo	Pos.	Código/Code	Descrição/Description	Med./Mes.
	09	0600.2104	Punho da Tocha Torch Handle	
	10	0600.1473	Terminal do Cabo Água e Força Rosca Esquerda Water and Power Cable Terminal	
	11	0600.1025	Mangueira de Água e Força p/Sistema Convencional e Engate Rápido 12,80mm Standard/Fast Coupling 12,80mm Water and Power Hose	
	12	0600.1026	Mangueira de Entrada de Água Convencional Standard Water Input Hose	
	13	0600.1126	Mangueira de Entrada de Água Engate Rápido Fast Coupling Water Input Hose	
	14	0600.1027	Mangueira de Gás Convencional Standard Gas Hose	
	15	0600.1127	Mangueira do Gás de Engate Rápido Fast Coupling Gas Hose	

Foto/Photo	Pos.	Código/Code	Descrição/Description	Med./Mes.
	16	0801.2092	Conector Macho TIG c/ Saída de Água Water Cooled Male Connector w/Water Exit	12,80mm
	17	0600.1091	Mangueira Vermelha de Saída de Água Engate Rápido Red Hose of Water exit w/Fast Coupling	0,80 mm
	18	0600.1022	Cabo de Acionamento 4m Trigger Cable 4m	
	19	0600.1023	Acionamento da Tocha Torch Trigger	
	20	0600.1028	Capa Protetora dos Cabos 3m Cable Protection Cover 3m	
	21	0600.1560	Isolação Termo Retrátil do Terminal Thermo Retractable Insulation	p/ metro



Características Técnicas Technical Data

Cinco Modelos de Corpo da Tocha em Ângulo Flexível e Reto - Five Models of Torch Bodies in Angle Flexible or Straight
Cordoalha Estanhada - Tinned Conductor
Corpo Interiço sem Solda - Body Made in a Single Part, Without Any Weld
Menos Aquecimento - Less Heat
Maior Passagem de Corrente - Improved Conductivity

Indicações Recommendation

Serviços Médios
Medium Works

Catálogo Digital
QR Code



Corrente - Current



DC



AC

1,0 - 3,17

Eletrodo (mm)
Electrode (mm)

E06/22-V4

Código/ Code	Descr./Descr.	Corpo/Body	Tipo/ Type	Engate/Coupling	Med./ Mes.	Estoque/ Stock
0600.7001				Convencional Standard		●
0600.7009	Tocha de Solda TIG SU26 SU26 TIG Welding Torch	Silicone Silicon	Registro Valve	Engate Rápido Fast Coupling	9,00mm	●
0600.7010					12,80mm	●

Tocha/Torch TIG Weld 26

Código/ Code	Descr./Descr.	Corpo/Body	Tipo/ Type	Engate/Coupling	Med./Mes.	Estoque/ Stock
0600.7002				Convencional Standard		●
0600.7011	Tocha de Solda TIG SU26 SU26 TIG Welding Torch	Silicone Silicon	Acionamento Trigger	Engate Rápido Fast Coupling	9,00mm	●
0600.7012					12,80mm	●

Tocha/Torch TIG Weld 26

Legenda/Legend: ● Produto Regular ● Produto Sob Demanda

Foto/Photo	Pos.	Código/Code	Descrição/Description	Med./Mes.
	01	0600.2119	Bocal de Cerâmica Alumina Nozzle	n° 04 ø6,5mm
		0600.2120		n° 05 ø8mm
		0600.2121		n° 06 ø9,5mm
		0600.2122		n° 07 ø11mm
		0600.2123		n° 08 ø12,5mm
		0600.2124		n° 10 ø16mm
	02	0600.2027	Corpo Fixador Collet Body	1,59mm 1/16"
		0600.2028		2,38mm 3/32"
		0600.2029		3,17mm 1/8"
	03	0600.1036	Anel Inferior Bottom Cup Gasket	

Foto/Photo	Pos.	Código/Code	Descrição/Description	Med./Mes.
	04	0600.1037	Corpo da Tocha Silicone Silicon Torch Body	p/uso de Registro w/Valve



CORPO PARA USO DE REGISTRO
Torch Body for Valve Use

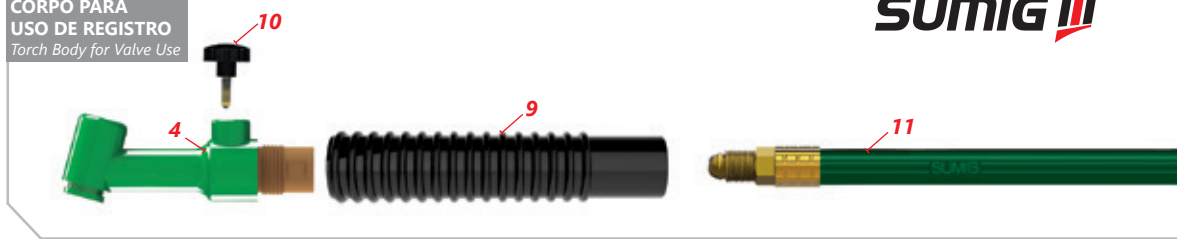

CORPO PARA USO DE ACIONAMENTO
Torch Body for Trigger Use

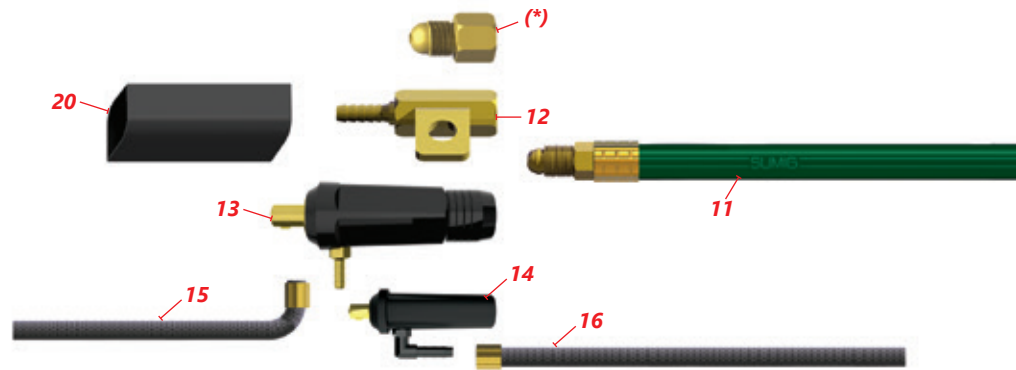
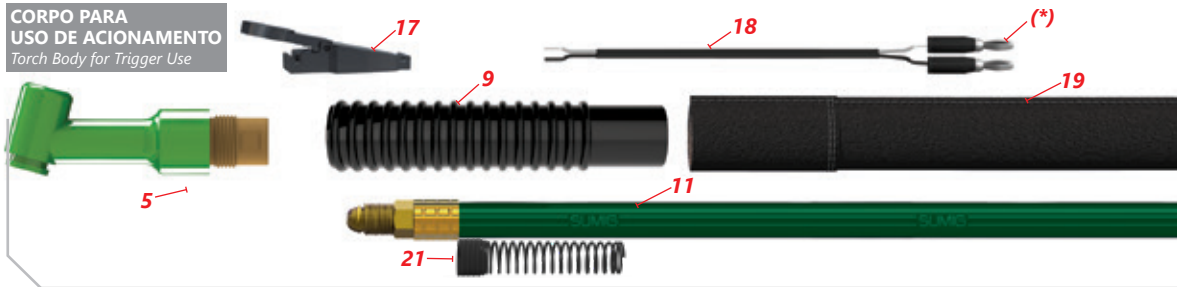

(*) Linha de Opcionais/Optional Line

Foto/Photo	Pos.	Código/Code	Descrição/Description	Med./Mes.
	06	0600.1043	Fixador Collet	1,00mm
		0600.2030		1,59mm 1/16"
		0600.1045		2,00mm 5/64"
		0600.2031		2,38mm 3/32"
		0600.2032		3,17mm 1/8"
	07	0600.2025	Capa Curta Short Cap	
	08	0600.2026	Capa Longa Long Cap	
	09	0600.2093	Punho da Tocha Torch Handle	
	10	0600.1054	Registro do Corpo Torch Valve	
	11	0600.1090	Cabo de Gás e Força p/Sistema Engate Rápido 9,00mm Gas-Power Cable for Standard System and 9,00mm Fast Coupling	
		0600.1053	Cabo de Gás e Força p/Sistema Convencional e Engate Rápido 12,80mm Gas-Power Cable for Standard System and 12,80mm Fast Coupling	

Foto/Photo	Pos.	Código/Code	Descrição/Description	Med./Mes.
	12	0600.1474	Terminal do Cabo Gás e Força Gas and Power Cable Terminal	
	13	0801.2085	Conector Macho TIG 12,80mm c/Entrada do Gás TIG Male Connector w/ 12,80mm Gas Input	
	14	0801.2090	Conector Macho TIG 9,00mm c/Entrada do Gás TIG Male Connector w/ 9,00mm Gas Input	
	16	0600.1093	Mangueira de Entrada do Gás Input Hose Gas	0,40m 3/16"
		0600.1669		1,50m 5/16"
		0600.1094		1,50m 3/16"
	17	0600.1023	Acionamento da Tocha Torch Trigger	
	18	0600.1022	Cabo de Acionamento 4m Trigger Cable 4m	
	19	0600.1060	Capa Protetora dos Cabos 3m Cable Protection Cover 3m	
	20	0600.1560	Isolação Termo Retrátil do Terminal Thermo Retractable Insulation	por metro
	21	0600.1583	Mola do Punho Handle Spring	



Características Técnicas Technical Data

Sete Modelos de Corpo da Tocha em ângulo, flexível ou reto - Seven Models of Torch Bodies in angle flexible or straight
Cordoalha Estanhada - Tinned Conductor
Corpo Interiço sem Solda - Body Made in a Single Part, Without Any Weld
Menos Aquecimento - Less Heat
Maior Passagem de Corrente - Improved Conductivity

Indicações Recommendation

Serviços Médios
Medium Works

Catálogo Digital
QR Code



Corrente - Current



1,0 - 3,97

Eletrodo (mm)
Electrode (mm)

E06/22-V4

Código/Code	Descr./Descr.	Corpo/Body	Tipo/Type	Engate/Coupling	Med./Mes.	Estoque/Stock
0600.7025	Tocha de Solda TIG SU27 SU27 TIG Welding Torch	Silicone Silicon	Registro Valve	Convencional Standard		●
0600.7026				Engate Rápido Fast Coupling	9,00mm	●
0600.7027			12,80mm		●	
0600.7028			Acionamento Trigger	Convencional Standard		●
0600.7029				Engate Rápido Fast Coupling	9,00mm	●
0600.7030					12,80mm	●

Tocha/Torch TIG SU27

Legenda/Legend: ● Produto Regular ● Produto Sob Demanda

Foto/Photo	Pos.	Código/Code	Descrição/Description	Med./Mes.	Foto/Photo	Pos.	Código/Code	Descrição/Description	Med./Mes.
	01	0600.2119	Bocal de Cerâmica Alumina Nozzle	n° 04 ø6,5mm		04	0600.1101	para uso de Registro with Valve	
		0600.2120		n° 05 ø8mm					
		0600.2122		n° 07 ø11mm					
		0600.2123		n° 08 ø12,5mm					
		0600.2124		n° 10 ø16mm					
		0600.2121		n° 06 ø9,5mm					
	02	0600.1098	Corpo Fixador Collet Body	1,59mm 1/16"		06	Fixador Collet	para uso de Acionamento for Trigger	
		0600.1099		2,38mm 3/32"					
		0600.1100		3,17mm 1/8"					
		0600.1111		3,97mm 5/32"					
		0600.1043		1,00mm					
	03	0600.1036	Anel Inferior Bottom Cup Gasket		0600.2030	1,59mm 1/16"			
				0600.1045	2,00mm 5/64"				
				0600.1046	2,38mm 3/32"				
				0600.1047	3,17mm 1/8"				
					0600.1048	3,97mm 5/32"			

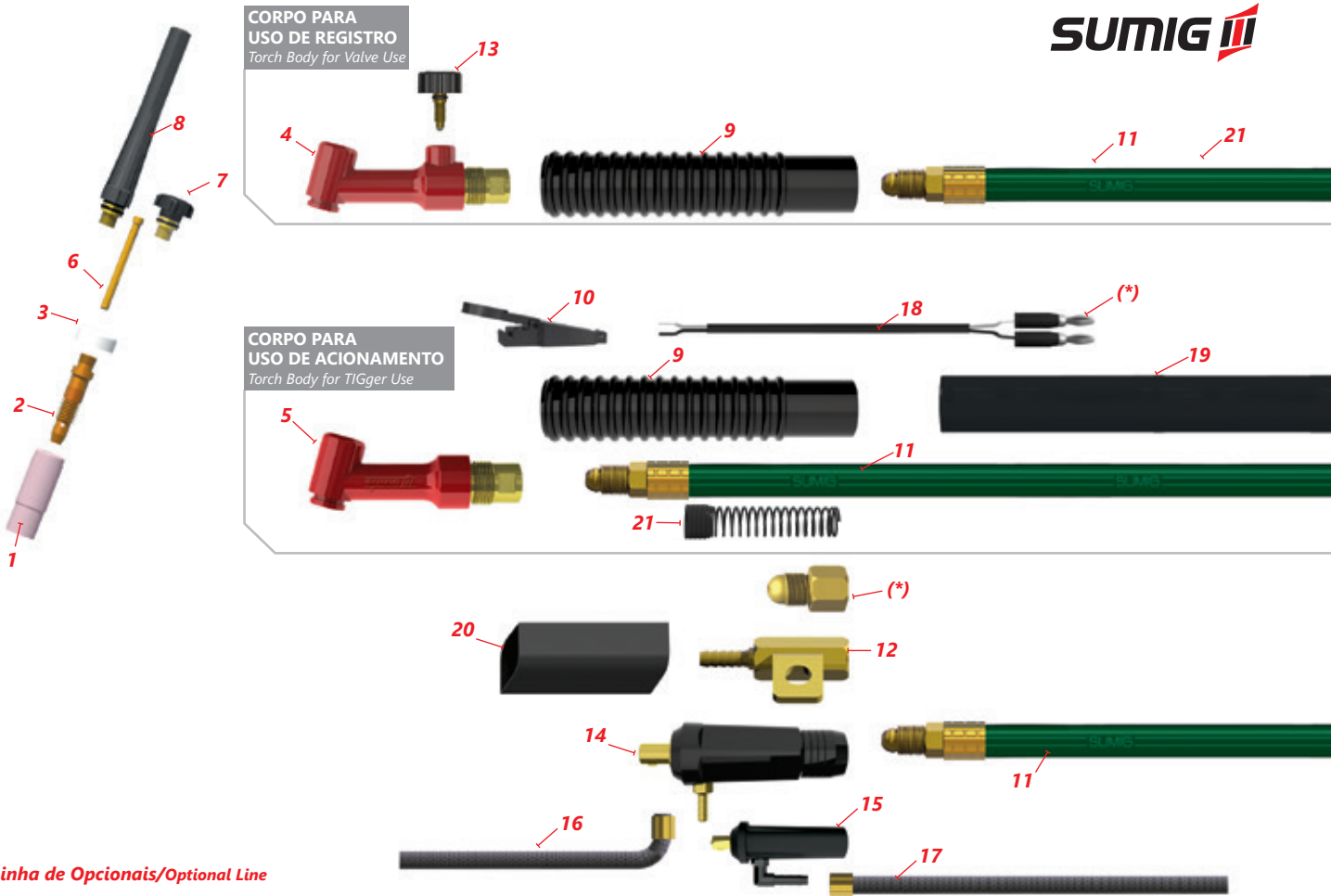

(*) Linha de Opcionais/Optional Line

Foto/Photo	Pos.	Código/Code	Descrição/Description	Med./Mes.
	07	0600.1109	Capa Curta Short Cap	
	08	0600.1110	Capa Longa Long Cap	
	09	0600.2093	Punho da Tocha Torch Handle	
	10	0600.1023	Acionamento da Tocha Torch Trigger	
	11	0600.1090	Cabo de Gás e Força p/Sistema Engate Rápido 9,00mm Gas-Power Cable for Standard System and 9,00mm Fast Coupling	
		0600.1053	Cabo de Gás e Força p/Sistema Convencional e Engate Rápido 12,80mm Gas-Power Cable for Standard System and 12,80mm Fast Coupling	
	12	0600.1474	Terminal do Cabo Gás e Força Gas and Power Cable Terminal	
	13	0600.1054	Registro do Corpo Torch Valve	
	14	0801.2085	Conector Macho TIG c/Entrada do Gás TIG Male Connector w/ Gas Input	12,80mm

Foto/Photo	Pos.	Código/Code	Descrição/Description	Med./Mes.
	15	0801.2090	Conector Macho TIG c/Entrada do Gás TIG Male Connector w/ Gas Input	9,00mm
	16	0600.1093	Mangueira de Entrada do Gás Input Hose Gas	0,40m 3/16"
		0600.1669		1,50m 5/16"
		0600.1094		1,50m 3/16"
	18	0600.1022	Cabo de Acionamento 4m Trigger Cable 4m	
	19	0600.1060	Capa Protetora dos Cabos Cable Protection Cover	
	20	0600.1560	Isolação Termo Retrátil do Terminal Thermo Retractable Insulation	p/ metro
	21	0600.1583	Mola do Punho Handle Spring	



Características Técnicas Technical Data

Dois Modelos de Corpo da Tocha com Ângulo ou Reto
Two Models of Torch Bodies in Angle or Straight
Cordoalha Estanhada
Tinned Conductor

Indicações Recommendation

Serviços Médios e Semi-Pesados
Medium Works

Catálogo Digital
QR Code



Corrente - Current



1,0 - 3,97

Eletrodo (mm)
Electrode (mm)

E06/22-V4

Código/Code	Descr./Descr.	Corpo/Body	Tipo/Type	Engate/Coupling	Med./Mes.	Estoque/Stock
0600.5001	Tocha de Solda TIG SU18 Refrigerada	Silicone Silicon	Acionamento Trigger	Convencional Standard		●
0600.5004	SU18 Water Cooled TIG Welding Torch			Engate Rápido Fast Coupling	12,80mm	●

Tocha/Torch TIG Weld 18

Legenda/Legend: ● Produto Regular ● Produto Sob Demanda

Foto/Photo	Pos.	Código/Code	Descrição/Description	Med./Mes.
	01	0600.2119	Bocal de Cerâmica Alumina Nozzle	n° 04 ø6,5mm
		0600.2120		n° 05 ø8mm
		0600.2121		n° 06 ø9,5mm
		0600.2122		n° 07 ø11mm
		0600.2123		n° 08 ø12,5mm
		0600.2124		n° 10 ø16mm
	02	0600.2027	Corpo Fixador Collet Body	1,59mm 1/16"
		0600.2028		2,38mm 3/32"
		0600.2029		3,17mm 1/8"
		0600.2043		3,97mm 5/32"

Foto/Photo	Pos.	Código/Code	Descrição/Description	Med./Mes.
	03	0600.1036	Anel Inferior Bottom Cup Gasket	
	04	0600.1056	Corpo da Tocha Silicone Silicon Torch Body for Trigger	p/uso de Acionamento w/Trigger
		0600.1043		1,00mm
		0600.2030		1,59mm 1/16"
	05	0600.1045	Fixador Collet	2,00mm 5/64"
		0600.2031		2,38mm 3/32"
		0600.2032		3,17mm 1/8"
		0600.2033		3,97mm 5/32"

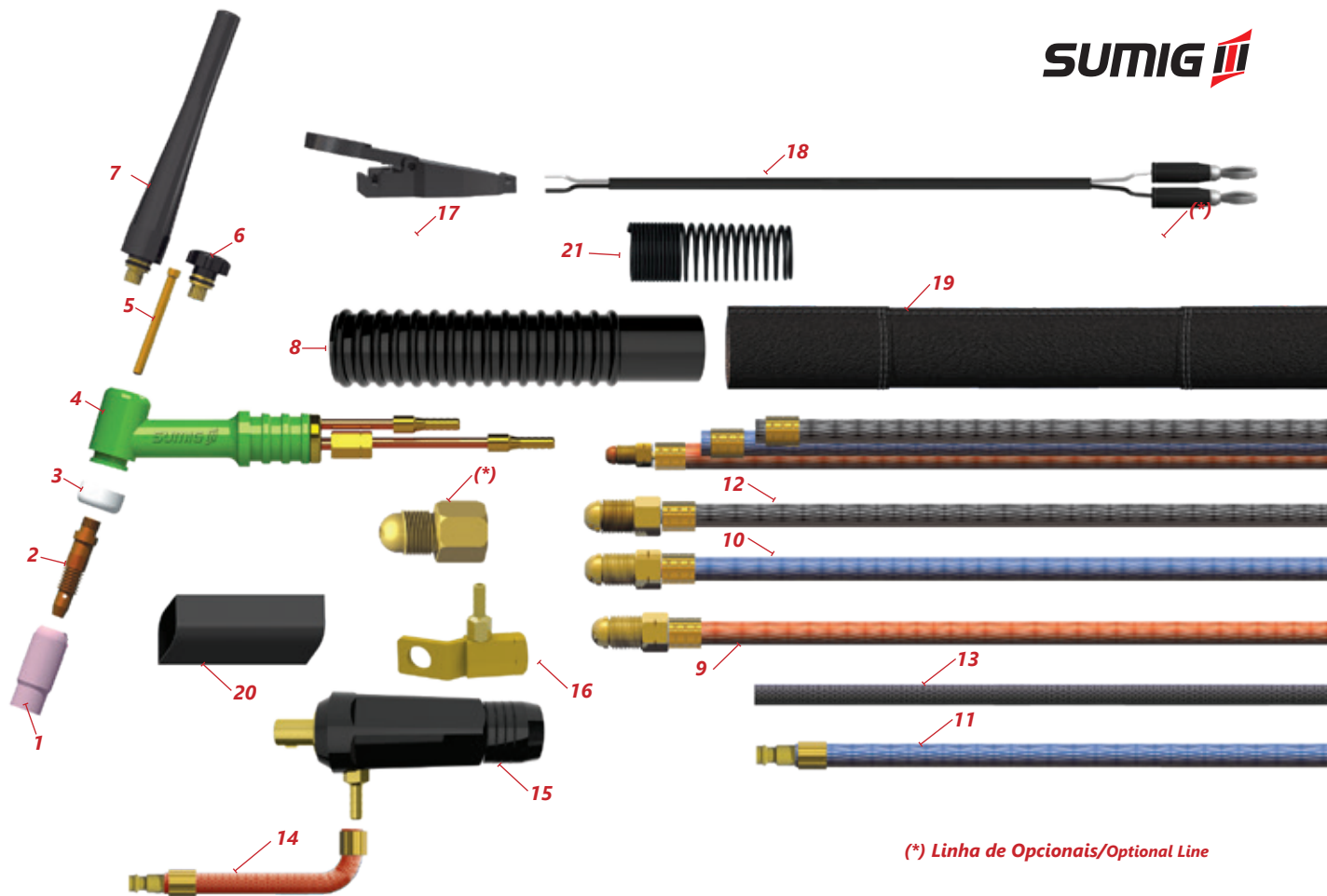

(*) Linha de Opcionais/Optional Line

Foto/Photo	Pos.	Código/Code	Descrição/Description	Med./Mes.
	06	0600.2025	Capa Curta Short Cap	
	07	0600.2026	Capa Longa Long Cap	
	08	0600.2203	Punho da Tocha Torch Handle	
	09	0600.1061	Mangueira de Água e Força p/Sistema Convencional e Engate Rápido 12,80mm Water and Power Hose for Standard System and 12,80mm Fast Coupling	12,80mm
	10	0600.1062	Mangueira Azul de Entrada de Água Convencional Blue Standard Water Input Hose	
	11	0600.1162	Mangueira Azul de Entrada de Água Engate Rápido Blue Fast Coupling Water Input Hose	
	12	0600.1063	Mangueira de Gás Convencional Standard Gas Hose	
	13	0600.1163	Mangueira do Gás de Engate Rápido Fast Coupling Gas Hose	

Foto/Photo	Pos.	Código/Code	Descrição/Description	Med./Mes.
	14	0600.1091	Mangueira Vermelha de Saída de Água Engate Rápido Red Exit Hose for Fast Coupling	0,80mm
	15	0801.2092	Conector Macho TIG Refrigerado c/Saída de Água Water Cooled Male Connector w/Water Exit	12,80mm
	16	0600.1473	Terminal do Cabo Água e Força Rosca Esquerda Water and Power Cable Terminal	
	17	0600.1023	Acionamento da Tocha Torch Trigger	
	18	0600.1022	Cabo de Acionamento 4m Trigger Cable 4m	
	19	0600.1060	Capa Protetora dos Cabos 3m Cable Protection Cover 3m	
	20	0600.1560	Isolação Termo Retrátil do Terminal Thermo Retractable Insulation	p/ metro
	21	0502.1456	Mola Dianteira Cable Front Spring	



Características Técnicas Technical Data

Três Modelos de Corpo da Tocha em Ângulo ou reto
Three Torch Bodies Models in Angle or Straight
Cordoalha Estanhada
Tinned Conductor
Rosca Grossa nos Consumíveis
Special Spiral

Indicações Recommendation

Serviços Médios e Semi-Pesados
Medium Works

Catálogo Digital
QR Code



Corrente - Current



1,0 - 4,76

Eletrodo (mm)
Electrode (mm)

E06/22-V4

Código/Code	Descr./Descr.	Corpo/Body	Tipo/Type	Engate/Coupling	Med./Mes.	Estoque/Stock
0600.5007	Tocha de Solda TIG SU19 Refrigerada	Silicone Silicon	Acionamento Trigger	Convencional Standard		●
0600.5008	SU19 Water Cooled TIG Welding Torch			Engate Rápido Fast Coupling	12,80mm	●

Tocha/Torch TIG SU19

Legenda/Legend: ● Produto Regular ● Produto Sob Demanda

Foto/Photo	Pos.	Código/Code	Descrição/Description	Med./Mes.
	01	0600.2119	Bocal de Cerâmica Alumina Nozzle	n° 04 ø6,5mm
		0600.2120		n° 05 ø8mm
		0600.2121		n° 06 ø9,5mm
		0600.2122		n° 07 ø11mm
		0600.2123		n° 08 ø12,5mm
		0600.2124		n° 10 ø16mm
	02	0600.1098	Corpo Fixador Collet Body	1,59mm 1/16"
		0600.1099		2,38mm 3/32"
		0600.1100		3,17mm 1/8"
		0600.1111		3,97mm 5/32"
		0600.1345		4,76mm 3/16"

Foto/Photo	Pos.	Código/Code	Descrição/Description	Med./Mes.
	03	0600.1036	Anel Inferior Bottom Cup Gasket	
	04	0600.1112	Corpo da Tocha Silicone Silicon Torch Body for Trigger	p/uso de Acionamento w/Trigger
		0600.1043		1,00mm
		0600.2030		1,59mm 1/16"
		0600.1045		2,00mm 5/64"
		0600.1046		2,38mm 3/32"
	05	0600.1047	Fixador Collet	3,17mm 1/8"
		0600.1048		3,97mm 5/32"
		0600.1337		4,76mm 3/16"

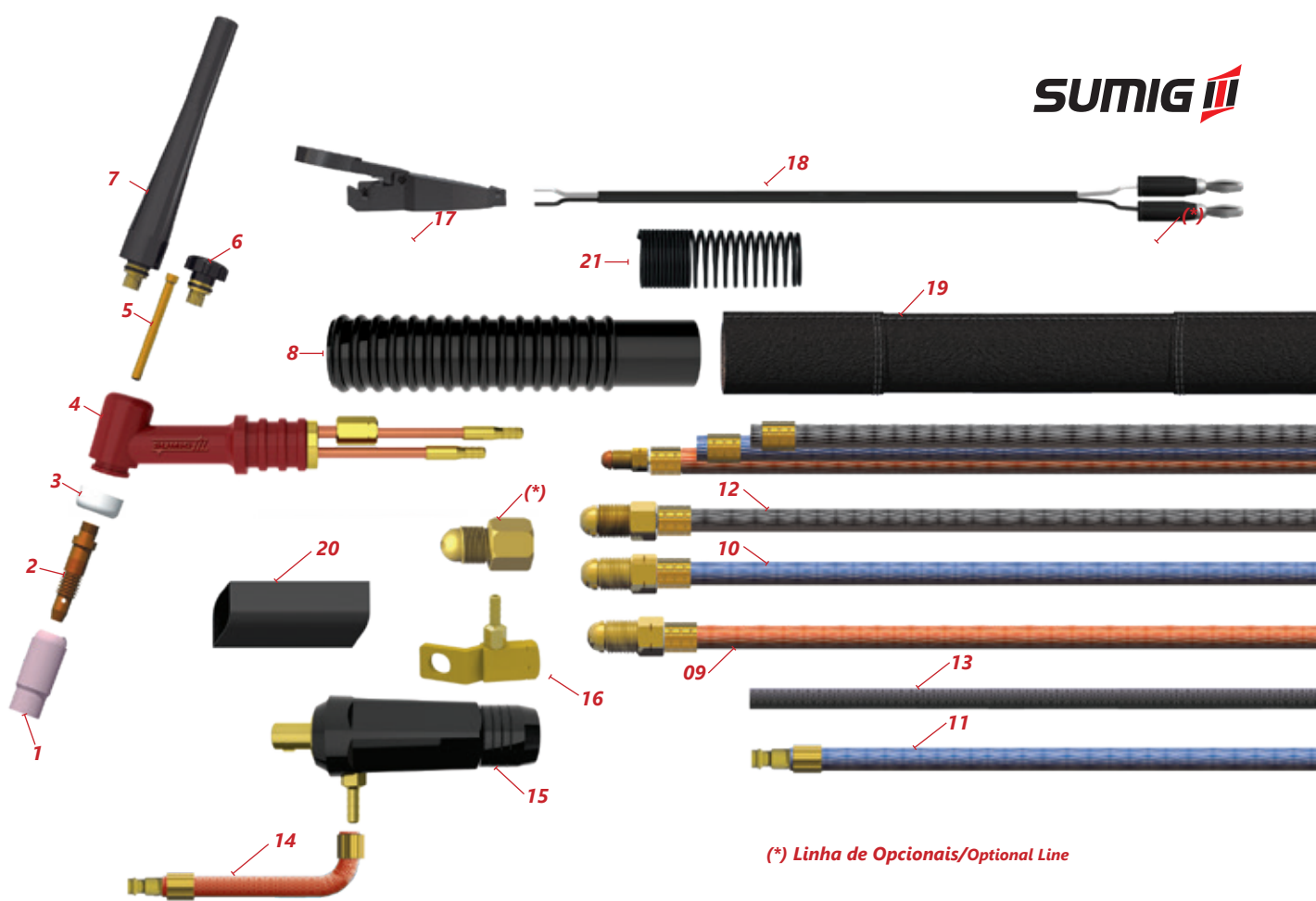

(*) Linha de Opcionais/Optional Line

Foto/Photo	Pos.	Código/Code	Descrição/Description	Med./Mes.
	06	0600.1109	Capa Curta Short Cap	
	07	0600.1110	Capa Longa Long Cap	
	08	0600.2203	Punho da Tocha Torch Handle	
	09	0600.1313	Mangueira de Água e Força p/Sistema Convencional e Engate Rápido 12,80mm Water and Power Hose for Standard System and 12,80mm Fast Coupling	12,80mm
	10	0600.1648	Mangueira Azul de Entrada de Água Convencional Blue Standard Water Input Hose	
	11	0600.1636	Mangueira Azul de Entrada de Água Engate Rápido Blue Fast Coupling Water Input Hose	
	12	0600.1027	Mangueira de Gás Convencional Standard Gas Hose	
	13	0600.1127	Mangueira do Gás de Engate Rápido Fast Coupling Gas Hose	

Foto/Photo	Pos.	Código/Code	Descrição/Description	Med./Mes.
	14	0600.1091	Mangueira Vermelha de Saída de Água Engate Rápido Red Exit Hose for Fast Coupling	0,80mm
	15	0801.2092	Conector Macho TIG Refrigerado c/Saída de Água Water Cooled Male Connector w/Water Exit	12,80mm
	16	0600.1473	Terminal do Cabo Água e Força Rosca Esquerda Water and Power Cable Terminal	
	17	0600.1023	Acionamento da Tocha Torch Trigger	
	18	0600.1022	Cabo de Acionamento 4m Trigger Cable 4m	
	19	0600.1060	Capa Protetora dos Cabos 3m Cable Protection Cover 3m	
	20	0600.1560	Isolação Termo Retrátil do Terminal Thermo Retractable Insulation	p/ metro
	21	0502.1456	Mola Dianteira Cable Front Spring	



Características Técnicas Technical Data

Três Modelos de Corpo da Tocha em Ângulo ou Reto
Three Models of Torch Bodies in Angle or Straight
Punho em Fibra de Vidro
Fiber Glass Handle
Cordoalha Estanhada
Tinned Conductor

Indicações Recommendation

Serviços Pesados
Heavy Works

Catálogo Digital
QR Code



Corrente - Current



1,59 - 4,76

Eletrodo (mm)
Electrode (mm)

E06/22-V4

Código/Code	Descr./Descr.	Corpo/Body	Tipo/Type	Engate/Coupling	Med./Mes.	Estoque/Stock
0600.8001	Tocha de Solda TIG SU40 SU40 TIG Welding Torch	Silicone Silicon	Registro Valve	Convencional Standard	12,80mm	●
0600.8006				Engate Rápido Fast Coupling		●
0600.8002			Acionamento Trigger	Convencional Standard	12,80mm	●
0600.8007				Engate Rápido Fast Coupling		●

Tocha/Torch TIG SU40

Legenda/Legend: ● Produto Regular ● Produto Sob Demanda

Foto/Photo	Pos.	Código/Code	Descrição/Description	Med./Mes.	Foto/Photo	Pos.	Código/Code	Descrição/Description	Med./Mes.
	01	0600.2151	Bocal de Cerâmica Alumina Nozzle	nº 04 ø6,5mm		04	0600.1070	Fixador Collet	1,59mm 1/16"
		0600.2152		nº 05 ø8mm			0600.1071		2,38mm 3/32"
		0600.2153		nº 06 ø9,5mm					
		0600.2154		nº 07 ø11mm					
		0600.2162		nº 08 ø12,5mm					
	02	0600.1075	Anel Inferior Bottom Cup Gasket						
	03	0600.1076	Corpo da Tocha Silicone Silicon Torch Body	p/uso de Registro w/Valve		04	0600.1072	Fixador Collet	3,17mm 1/8"
		0600.1077		p/uso de Aciona- mento for Trigger			0600.1073		3,97mm 5/32"
							0600.1190		4,76mm 3/16"

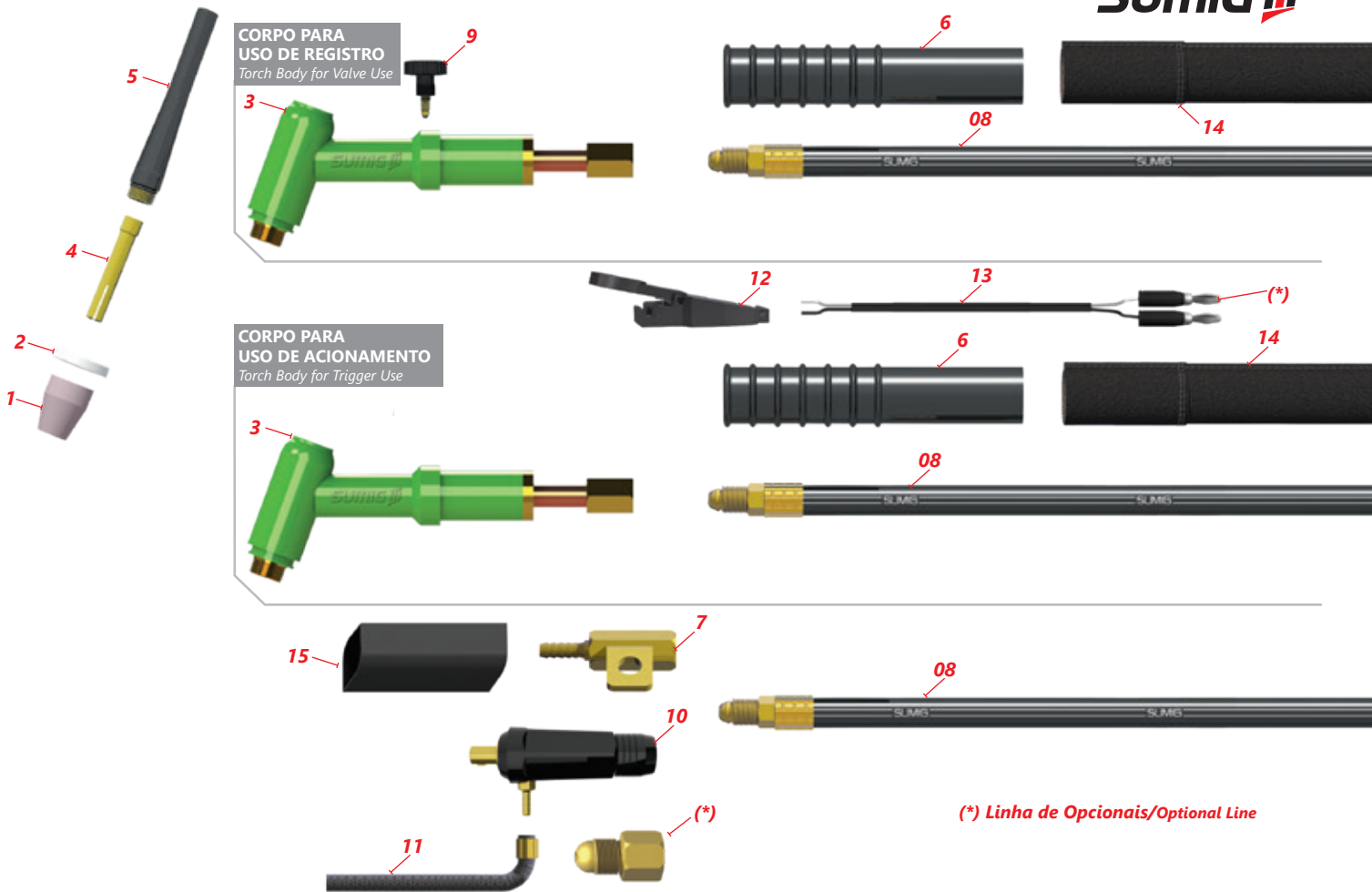

(*) Linha de Opcionais/Optional Line

Foto/Photo	Pos.	Código/Code	Descrição/Description	Med./Mes.
	05	0600.2052	Capa Longa Long Cap	
	06	0600.1082	Punho da Tocha Torch Handle	
	07	0600.1474	Terminal do Cabo Gás e Força Gas and Power Cable Terminal	
	08	0600.1083	Cabo Gás e Força Gas and Power Cable	
	09	0600.1198	Registro do Corpo Torch Valve	
	10	0801.2085	Conector Macho TIG Refrigerado c/ Entrada de Gás Water Cooled Male Connector w/Water Exit	12,80mm

Foto/Photo	Pos.	Código/Code	Descrição/Description	Med./Mes.
	11	0600.1093	Mangueira de Entrada do Gás Gas Input Hose	0,40m 3/16"
		0600.1669		1,50m 5/16"
	12	0600.1023	Acionamento da Tocha Torch Trigger	
	13	0600.1022	Cabo do Acionamento 4m Trigger Cable 4m	
	14	0600.1085	Capa Protetora dos Cabos 3m Cable Protection Cover 3m	
	15	0600.1560	Isolação Termo Retrátil do Terminal Thermo Retractable Insulation	p/ metro



Características Técnicas Technical Data

Dois Modelos de Corpo da Tocha em Ângulo ou Reto
Two Models of Torch Bodies in Angle or Straight
Punho em Fibra de Vidro
Fiber Glass Handle
Cordoalha Estanhada
Tinned Conductor

Indicações Recommendation

Serviços Pesados
Heavy Works

Catálogo Digital
QR Code



Corrente - Current



1,59 - 4,76

Eletrodo (mm)
Electrode (mm)

E06/22-V4

Código/Code	Descr./Descr.	Corpo/Body	Tipo/Type	Engate/Coupling	Med./Mes.	Estoque/Stock
0600.9001	Tocha de Solda TIG SU50 Refrigerada	Silicone Silicon	Acionamento Trigger	Convencional Standard		●
0600.9004	SU50 Water Cooled TIG Welding Torch			Engate Rápido Fast Coupling	12,80mm	●

Tocha/Torch TIG SU50 Refrigerada

Legenda/Legend: ● Produto Regular ● Produto Sob Demanda

Foto/Photo	Pos.	Código/Code	Descrição/Description	Med./Mes.
	01	0600.2151	Bocal de Cerâmica Alumina Nozzle	n° 04 ø6,5mm
		0600.2152		n° 05 ø8mm
		0600.2153		n° 06 ø9,5mm
		0600.2154		n° 07 ø11mm
		0600.2162		n° 08 ø12,5mm
	02	0600.1075	Anel Inferior Bottom Cup Gasket	
	03	0600.1087	Corpo da Tocha Silicone Silicon Torch Body	p/uso de Acionamento for Trigger

Foto/Photo	Pos.	Código/Code	Descrição/Description	Med./Mes.
	04	0600.1070	Fixador Collet	1,59mm 1/16"
		0600.1071		2,38mm 3/32"
		0600.1072		3,17mm 1/8"
		0600.1073		3,97mm 5/32"
		0600.1190		4,76mm 3/16"
		0600.1279		6,35mm 1/4"
	05	0600.2052	Capa Longa Long Cap	

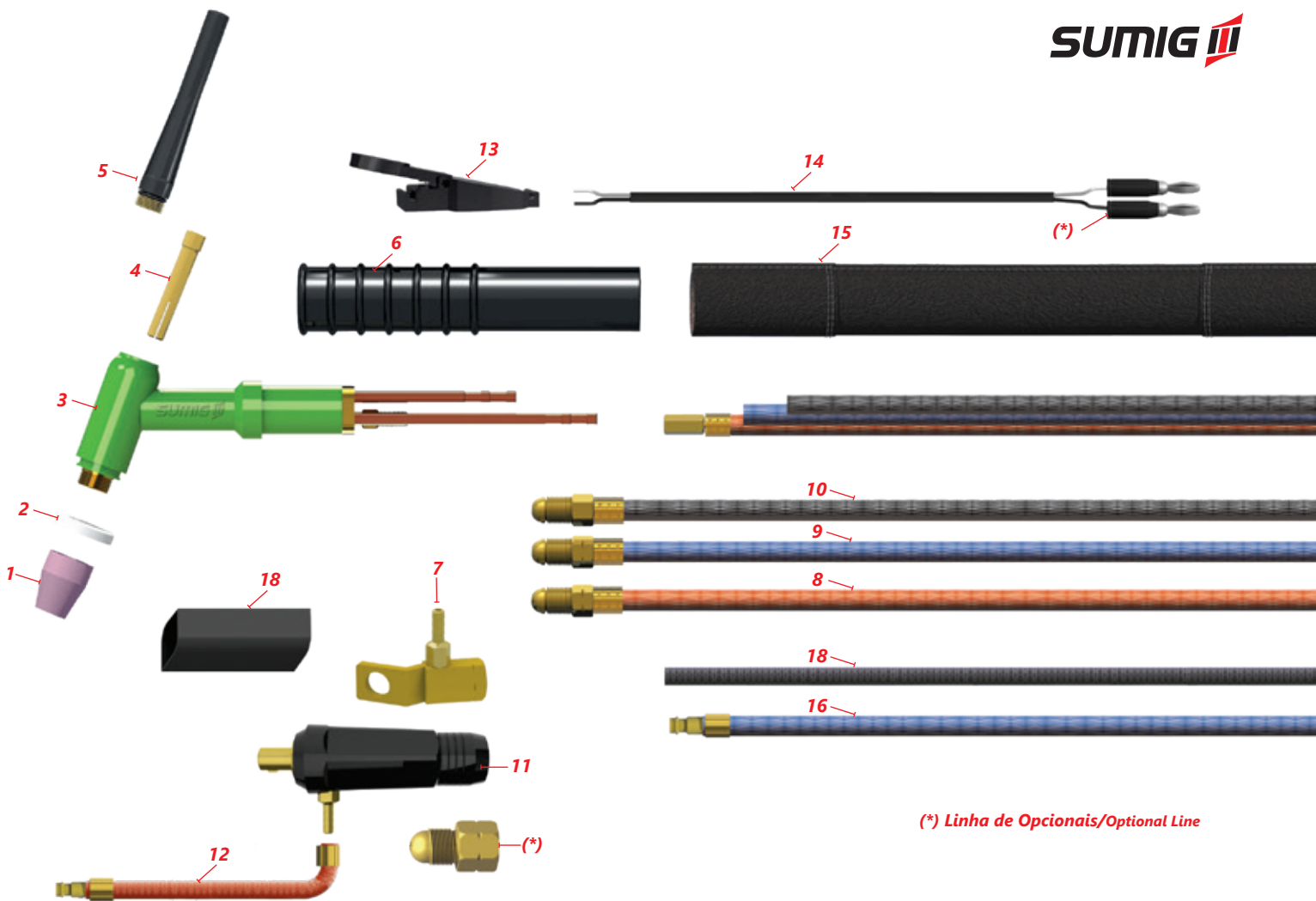

(*) Linha de Opcionais/Optional Line

Foto/Photo	Pos.	Código/Code	Descrição/Description	Med./Mes.
	06	0600.1082	Punho da Tocha Torch Handle	
	07	0600.1473	Terminal do Cabo Água e Força Rosca Esquerda Water and Power Cable Terminal	
	08	0600.1089	Mangueira de Água e Força p/ Sistema Convencional e Eng. Rápido 12,80mm Water and Power Hose for Standard System and 12,80mm Fast Coupling	
	09	0600.1062	Mangueira Azul de Entrada de Água/Convencional Blue Standard Water Input Hose	
	10	0600.1063	Mangueira de Gás/Convencional Standard Gas Hose	
	11	0801.2092	Conector Macho TIG Refrigerado c/Saída de Água Water Cooled Male Connector w/Water Exit	12,80mm
	12	0600.1091	Mangueira Vermelha de Saída de Água Engate Rápido Red Hose of Water Exit for Fast Coupling	0,80mm

Foto/Photo	Pos.	Código/Code	Descrição/Description	Med./Mes.
	13	0600.1023	Acionamento da Tocha Torch Trigger	
	14	0600.1022	Cabo de Acionamento 4m Trigger Cable 4m	
	15	0600.1085	Capa Protetora dos Cabos 3m Cable Protection Cover 3m	
	16	0600.1162	Mangueira Azul de Entrada de Água/Engate Rápido Blue Fast Coupling Water Input Hose	
	17	0600.1163	Mangueira do Gás Engate Rápido Fast Coupling Gas Hose	
	18	0600.1560	Isolação Termo Retrátil do Terminal Thermo Retractable Insulation	por metro per meter

APLICAÇÕES ESPECIAIS

SU27 PRECISION



Características Técnicas Technical Data

Cabo Ultra Flexível - *Ultra flexible cable*
Consumíveis Rosca Grossa para Maior Durabilidade
Spare parts with Special Threads that Gives Higher Durability
Sete Modelos de Corpo da Tocha em Ângulo, flexíveis ou reto - *Seven Models in Torch Bodies in angle, flexible or straight*
Cordoalha Estanhada - *Tinned Conductor*
Corpo Interiço sem Solda - *Body Made in a Single Part, Without Any Weld*
Menor Aquecimento - *Less Heat*
Maior Passagem de Corrente - *Improved Conductivity*

Indicações Recommendation

Serviços Médios
Medium Works

Catálogo Digital
QR Code



Corrente - Current

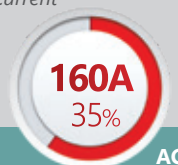

1,0 - 3,97

Eletrodo (mm)
Electrode (mm)

E06/22-V4

SU27 MAX



Características Técnicas Technical Data

Dois Modelos de Corpo da Tocha em Cobre - *Two Models of Torch Bodies in Copper*
Cordoalha Dupla Estanhada - *Double Tinned Conductor*
Corpo Interiço sem Solda - *Body Made in a Single Part, Without Any Weld*
Menos Aquecimento - *Less Heat*
Maior Passagem de Corrente - *Improved Conductivity*
Punho Resistente ao Calor - *Handle Heat-Resistant*

Indicações Recommendation

Serviços Médios e
Semi pesados
*Medium and
Semi heavy works*

Catálogo Digital
QR Code



Corrente - Current

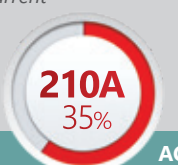
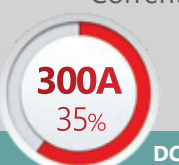

1,0 - 3,97

Eletrodo (mm)
Electrode (mm)

E06/22-V4

SR82 MECANIZAÇÃO



Características Técnicas Technical Data

Desenvolvida para Trabalhar com Altos Ciclos de Trabalho
Developed for High Cycle Works
Troca Rápida do Eletrodo de Tungstênio
Easy Electrode Substitution

Indicações Recommendation

Mecanização em Geral
Automatic Works

Catálogo Digital
QR Code



Corrente - Current



1,59 - 4,76

Eletrodo (mm)
Electrode (mm)

E06/22-V4

OPCIONAIS

● Itens de Série
Standard

● Opcionais
Optional

Foto
Photo

Descrição
Description

Código
Code

SU
9

SU
20

SU
26

SU
27

SU
27P

SU
18

SU
19

SU
40

SU
50

SR
82

E06/22-V4

Bocais de Cerâmica/Alumina Nozzle



n° 04 13N08	0600.2105	●	●															
n° 05 13N09	0600.2106	●	●															
n° 06 13N10	0600.2107	●	●															
n° 07 13N11	0600.2108	●	●															
n° 08 13N12	0600.2109	●	●															



n° 04 10N50	0600.2119			●	●	●	●	●										
n° 05 10N49	0600.2120			●	●	●	●	●										
n° 06 10N48	0600.2121			●	●	●	●	●										
n° 06 10N48 L	0600.2144			●	●	●	●	●										
n° 07 10N47	0600.2122			●	●	●	●	●										
n° 07 10N47 L	0600.2141			●	●	●	●	●										
n° 08 10N46	0600.2123			●	●	●	●	●										
n° 10 10N45	0600.2124			●	●	●	●	●										



n° 04 14N57	0600.2151														●	●		
n° 05 14N58	0600.2152														●	●		
n° 06 14N59	0600.2153														●	●		
n° 07 14N60	0600.2154														●	●		
n° 08 14N61	0600.2162														●	●		
n° 10 14N61	0600.2156														●	●		



n° 04 14N57	0600.2158														●	●		
n° 05 14N58	0600.2159														●	●		
n° 06 14N59	0600.2160														●	●		
n° 07 14N60	0600.2161														●	●		
n° 08 14N61	0600.2162														●	●		
n° 10 14N61	0600.2163														●	●		

 Itens de Série Standard

 Opcionais Optional

RELAÇÃO DE TOCHAS

Foto Photo	Descrição Description	Código Code	SU 9	SU 20	SU 26	SU 27	SU 27P	SU 18	SU 19	SU 40	SU 50	SR 82
	nº 04 53N58	0600.2112	●	●								
	nº 05 53N59	0600.2113	●	●								
	nº 06 53N60	0600.2114	●	●								
	nº 07 53N61	0600.2115	●	●								
	nº 05 54N17	0600.2127			●	●	●	●	●			
	nº 06 54N16	0600.2128			●	●	●	●	●			
	nº 07 54N15	0600.2129			●	●	●	●	●			
	nº 08 54N14	0600.2130			●	●	●	●	●			





Bocais Super Gás Lens/Gas Lens Alumina Nozzle

	nº 06 53N75	0600.2136			●	●	●	●	●			●
	nº 08 53N74	0600.2131			●	●	●	●	●			●
	nº 10 53N88	0600.2132			●	●	●	●	●			●
	nº 12 53N87	0600.2133			●	●	●	●	●			●











 Itens de Série Standard

 Opcionais Optional

RELAÇÃO DE TOCHAS

Foto Photo	Descrição Description	Medidas Measure	Código Code	SU 9	SU 20	SU 26	SU 27	SU 27P	SU 18	SU 19	SU 40	SU 50
	Corpo Fixador Collet Body	1,59mm - 1/16"	0600.2016	●	●							
		2,38mm - 3/32"	0600.2017	●	●							
		3,17mm - 1/8"	0600.2044		●							
	Corpo Fixador Collet Body	1,59mm - 1/16"	0600.2027			●			●			
		2,38mm - 3/32"	0600.2028			●			●			
		3,17mm - 1/8"	0600.2029			●			●			
		3,97mm - 5/32"	0600.2043			●			●			
	Corpo Fixador Rosca Grossa Collet Body w/Special Spiral	1,59mm - 1/16"	0600.1098				●	●		●		
		2,38mm - 3/32"	0600.1099				●	●		●		
		3,17mm - 1/8"	0600.1100				●	●		●		
		3,97mm - 5/32"	0600.1111				●	●		●		
	Difusor de Gás da Tocha Reta Straight Torch Gas Diffuser		0600.1074								●	●
	Difusor Gás Lens Gas Lens Diffuser	1/16" - 45V43	0600.2110	●	●							
		3/32" - 45V44	0600.2111	●	●							
		1/8" - 45V45	0600.2116		●							
	Difusor Gás Lens Gas Lens Diffuser	1/16" - 45V25	0600.2138			●			●			
		3/32" - 45V26	0600.2125			●			●			
		3/32" - 45V26 Rosca Grossa	0600.2145				●	●		●		
		1/8" - 45V27	0600.2126			●			●			
		1/8" - 45V27 Rosca Grossa	0600.2146				●	●		●		
	Difusor Super Gás Lens Gas Lens Diffuser	3/32" - 45V64	0600.2134			●			●			
		3/32" - 45V64 Rosca Grossa	0600.2147				●	●		●		
		1/8" - 995795	0600.2135			●			●			
		1/8" - 995795 Rosca Grossa	0600.2148				●	●		●		





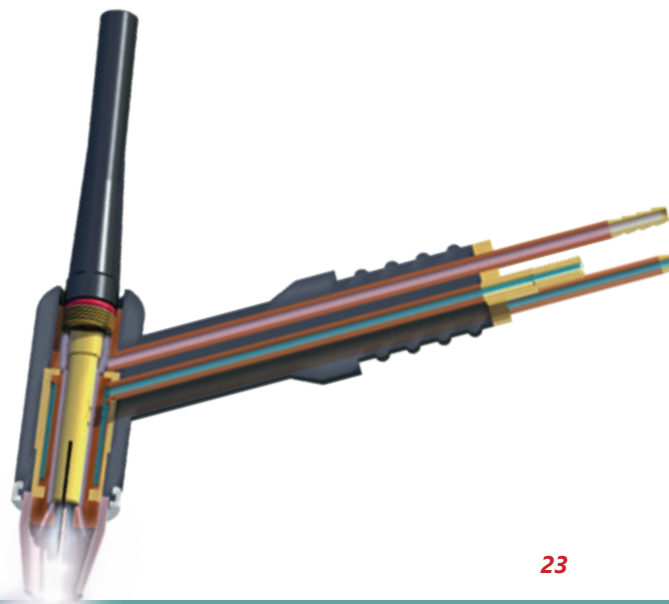

RELAÇÃO DE TOCHAS

Foto Photo	Descrição Description	Código Code	SU 9	SU 20	SU 26	SU 27	SU 27P	SU 18	SU 19	SU 40	SU 50	SR 82
	Plug para Acionamento TIG na Máquina Plug for TIG Machine Connection	4003.0010	●	●	●	●		●	●	●	●	
	Niple Plástico "L" TIG E/R 9,00 mm Plastic Nipple 9,00 mm	0801.2097	●		●	●						
	Niple de Gás E/R 12,00 mm Plug for Gas 12,00 mm	2430.0010	●	●	●	●	●	●	●	●	●	●
	Engate Rápido 3/16" 3/16" Fast Coupling	0500.1328						●	●		●	●
	Engate Rápido 5/32" 5/32" Fast Coupling	2250.0328		●								
	Cremalheira com Parafusos Gear w/Screw	0500.1185									●	●
7/8" Esq.  5/8" Esq.	Adaptador Rosca Esq. Cabo de Água e Força Left Spiral Adaptor for Power and Water Cable	0600.2103			●				●	●		●
7/8" Dir.  5/8" Esq.	Adaptador Rosca Esq. Cabo de Água e Força Left Spiral Adaptor for Power and Water Cable	2250.0029			●				●	●		●
7/8" Dir.  5/8" Dir.	Adaptador Rosca Dir. Cabo de Gás e Força Right Spiral Adaptor for Power and Gas Cable	2250.0025	●		●	●					●	
M16  5/8" Dir.	Adaptador TIG Direita Right TIG Adapter	2260.0039	●		●	●					●	
M16  5/8" Esq.	Adaptador TIG Esquerda Left TIG Adapter	2260.0047		●					●			●













EO6/22-V4





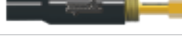

RELAÇÃO DE TOCHAS

Foto Photo	Descrição Description	Medidas Measure	Código Code	SU 9	SU 20	SU 17	SU 26	SU 27	SU 18	SU 19	SU 40	SU 50
	Anel Inferior Bottom Cup Gasket		0600.1004	●	●							
	Anel Inferior Bottom Cup Gasket		0600.1036			●	●	●	●	●		
	Anel Inferior Bottom Cup Gasket		0600.1075								●	●
	Anel p/ Difusor de Gás Lens Gas Lens Cup Gasket		0600.1215	●	●							
	Anel p/ Difusor de Gás Lens Gas Lens Cup Gasket		0600.2140			●	●	●	●	●		
	Anel p/ Difusor de Super Gás Lens Super Gas Lens Cup Gasket		0600.2137			●	●	●	●	●		

E06/22-V4

Foto/Photo	Descrição/Description	Código/Code
	Corpo das Tocha Reto SU 9 SU 9 Straight Torch Body	0600.1008
	Corpo das Tocha Reto SU 20 SU 20 Straight Torch Body	0600.1031
	Corpo das Tocha Reto SU 26 SU 26 Straight Torch Body	0600.1041
	SU 27 Flexível para Registro SU 27 Flexible Torch Body with valve	0600.1105
	SU 27 Flexível para Acionamento SU 27 Flexible Torch Body for Trigger	0600.1106
	Corpo das Tocha Reto SU 27 SU 27 Straight Torch Body	0600.1107
	Corpo das Tocha Reto SU 18 SU 18 Straight Torch Body	0600.1058
	Corpo das Tocha Reto SU 19 SU 19 Straight Torch Body	0600.1114
	Corpo das Tocha Reto SU 40 SU 50 Straight Torch Body	0600.1080
	Corpo das Tocha Reto SU 50 SU 50 Straight Torch Body	0600.1084
	Corpo 90° da Tocha Silicone SU 27 para registro SU 27 Silicon Torch Body 90° with valve	0600.1323
	Corpo 90° da Tocha Silicone SU 27 para acionamento SU 27 Silicon Torch Body 90° for trigger	0600.1322
	Corpo 90° da Tocha SU 19 Silicone para acionamento SU 19 Silicon Torch Body 90° for trigger	0600.1518

Foto/Photo	Descrição/Description	Código/Code
	SU 9 Flexível para Registro SU 9 Flexible Torch Body with valve	0600.1064
	SU 9 Flexível para Acionamento SU 9 Flexible Torch Body for Trigger	0600.1065
	SU 26 Flexível para Registro* SU 26 Flexible Torch Body with valve	0600.2023
	SU 26 Flexível para Acionamento* SU 26 Flexible Torch Body for Trigger	0600.2042

*Necessário uso do punho código 0600.2035

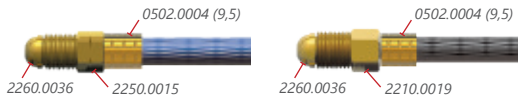
Foto Photo	SU 9	SR 24	SU 20	SU 25W	SU 17	SU 26	SU 27	SU 18	SU 19	SU 50	SR 82	
Reposição Mangueiras de Refrigeração e Gás/Cooling and Gas Hoses Replacement												
												
												

Montagem Gás Lens/Gas Lens Assembly

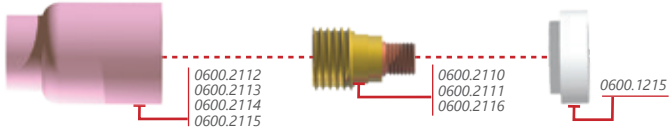
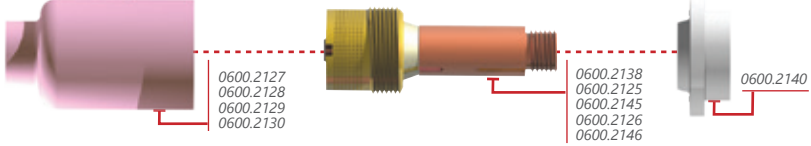
Montagem Super Gás Lens/Super Gas Lens Assembly

											
------------------------------------------------------------------------------------	--	--	--	--	--	--	--	--	--	--	--

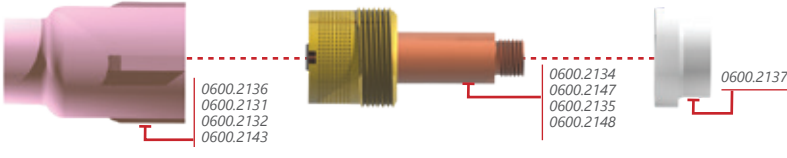

Fundada em 1980, a Sumig é estruturada para oferecer soluções para solda e corte, com produtos que atendem os mais diferentes níveis tecnológicos e necessidades das aplicações.

Com produtos de última geração, a empresa está em contínua expansão e é líder do segmento no mercado brasileiro. No mercado internacional a Sumig tem forte atuação com parcerias firmadas em todos os continentes.



Tochas de Solda e Corte



Máquinas de Solda e Corte



Soldagem Robotizada



Corte Plasma



Acessórios Para Soldagem



Serviços 360



Curta nosso canal no Youtube e fique por dentro do mundo da soldagem!



[Youtube.com/Sumig](https://www.youtube.com/Sumig)

www.sumig.com

SUMIG MATRIZ

AV. ÂNGELO CORSETTI, 1281
B. PIONEIRO | CEP 95042-000
CAXIAS DO SUL - RS
FONE/FAX: (54) 3220.3900
VENDAS@SUMIG.COM

SUMIG SÃO PAULO

ALAMEDA VÊNUS, 360
B. AMERICAN PARK EMPRESARIAL NR
CEP 13347-659 - INDAIATUBA - SP
FONE: (19) 4062.8900
FILIALSP@SUMIG.COM

SUMIG USA

1504 EAGLE CT. STE 8
LEWISVILLE, TX, 75057
PHONE: +1(800) 503 9717
WWW.SUMIGUSA.COM
SUMIGUSA@SUMIG.COM

ACOMPANHE NOSSAS REDES SOCIAIS



[Facebook.com/SumigBrasil](https://www.facebook.com/SumigBrasil)



[Instagram.com/SumigBrasil](https://www.instagram.com/SumigBrasil)



[Youtube.com/Sumig](https://www.youtube.com/Sumig)



[LinkedIn.com/Sumig](https://www.linkedin.com/Sumig)

SUMIG III